

REV.NO.	DESCRIPTION	PREVIOUS DWG	BY	DATE

ITEM	QTY.	REF.	DESCRIPTION

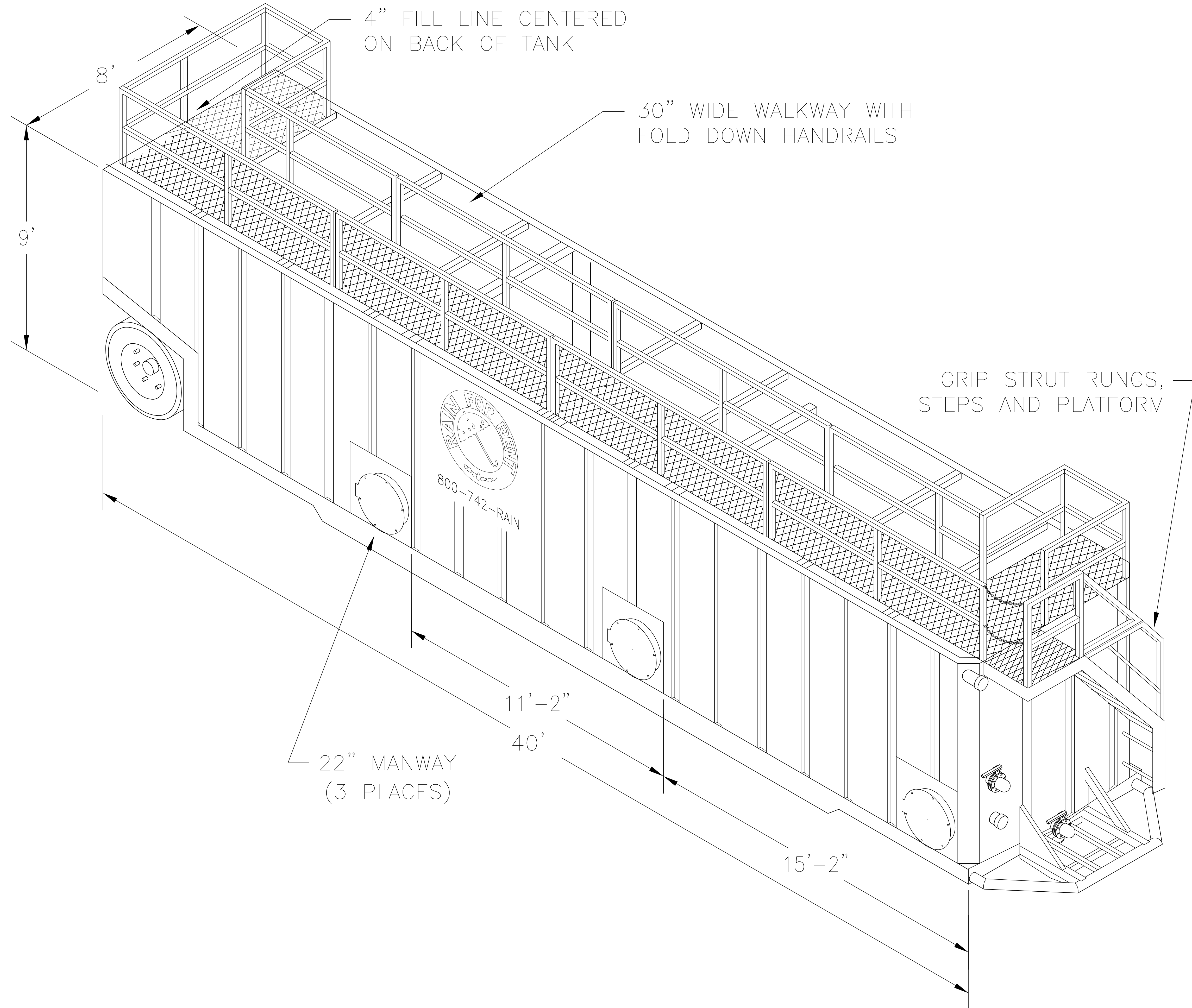

DATE:	3-25-03
SCALE:	NTS
DESIGNED:	
CHECKED:	
DRAWN:	S.HERNANDEZ

OPEN TOP TANK

18,100 GALLON WORKSAFE TANK
DETAIL

**Rain For Rent
Engineering**
3404 STATE ROAD PO BOX 2248 BAKERSFIELD CA 93303

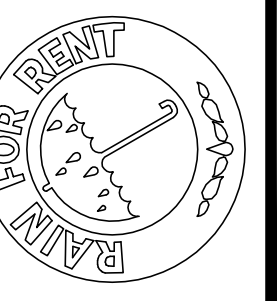

ALL INFORMATION CONTAINED IN OR REFERRED TO IN THIS DOCUMENT IS THE PROPERTY OF RAIN FOR RENT. ALL RIGHTS ARE RESERVED. REPRODUCTION AND REPRODUCTION OF THIS DOCUMENT WITHOUT THE WRITTEN CONSENT OF RAIN FOR RENT IS PROHIBITED WITHOUT THE PRIOR WRITTEN CONSENT OF RAIN FOR RENT.

1	SHEET	1
DRAWING NUMBER		
103421		
JOB NUMBER		
1030004		